

Safety valves
made of stainless steel,
atmospheric discharge,
with threaded connections

FIG. 327.2

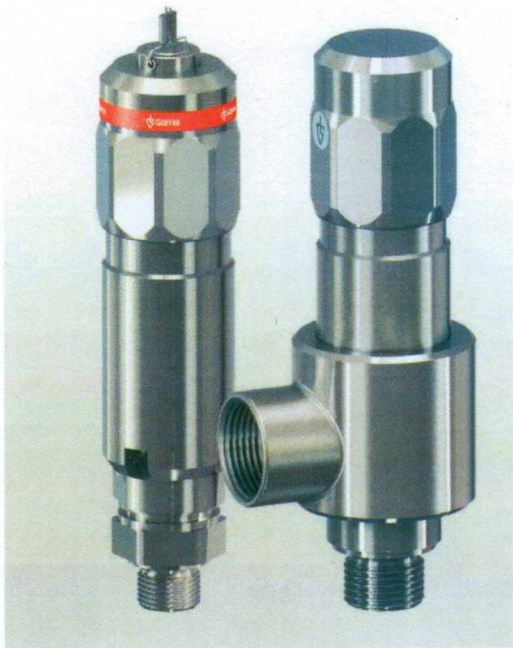

■ SUITABLE FOR

Air, gases and vapours neutral and non-neutral



■ EXAMPLES OF USE

For the protection of:

- pressure tanks and
 - pressure systems
- for air and other neutral and non-neutral gases.

Please observe plant-specific regulations and use of appropriate valve version and sealing material.

- high-pressure compressors
- pressure tanks
- pressure cylinder pack

Safety valves are set and sealed at the factory.



■ MATERIAL



■ SPECIFICATION



1/4" – 3/4"



– 60°C to + 180°C



50 – 630 bar
depending on version

■ APPROVALS

TÜV Type test approval 2076	D/G
EC type examination	S/G
TR ZU 032/2013 - TR ZU 010/2011	D/G (S/G)

Requirements

AD 2000 Data sheet A2
DIN EN ISO 4126-1
PED 2014/68/EU

Classification society

Germanischer Lloyd	GL
Det Norske Veritas	DNV
Russian Maritime Register of Shipping	RS
Lloyd's Register EMEA	LR EMEA

■ MATERIALS

Component	Material	DIN EN	ASME
Inlet body	Stainless steel	1.4404	316 L
Outlet body	Stainless steel	1.4404	316 L
Internal parts	Stainless steel	1.4404	316 L
Spring	Spring steel	VDSiCr	

■ VALVE VERSION

s	Standard	cylindrical form, atmospheric discharge, for air and similar neutral, non-toxic and non-flammable gases that can be freely discharged into the atmosphere.
t	gastight version of spring housing	for neutral and non-neutral media, not counter pressure compensated. The environment is protected from being affected by the medium. Only available for version with angled body and without lifting device.

■ MEDIUM

G	gaseous	Air and similar neutral and non-neutral gases
---	---------	---

■ TYPE OF LIFTING MECHANISM

K	Standard with twist-type lifting mechanism
0	without lifting device

■ AVAILABLE NOMINAL DIAMETERS AND CONNECTION SIZES

Nominal diameter DN		10				15		
Inlet		1/4" (8)	3/8" (10)	1/2" (15)	3/4" (20)	3/8" (10)	1/2" (15)	3/4" (20)
Outlet	Atmospheric discharge via outlet apertures	■	■	■	■	■	■	■
	1/2" (15)	■	■	■	■	■	■	■
	3/4" (20)	■	■	■	■	■	■	■
	1" (25)	■	■	■	■	■	■	■

■ TYPE OF CONNECTION INLET / OUTLET THREADED CONNECTIONS

m/-	Standard	Male thread BSP-P / -	DIN EN ISO 228-1 / -
m/f	with positionable angled body	Male thread BSP-P / Female thread BSP-P	DIN EN ISO 228-1 / DIN EN ISO 228-1

■ SEALS

MD / PAI	Metal-to-metal sealing / Polyamidimide	Flat seal 50 - 630 bar	-60°C to +180°C
----------	--	------------------------	-----------------

■ OPTIONS

Special versions on request.

■ NOMINAL DIAMETERS, CONNECTIONS, INSTALLATION DIMENSIONS

Series		Connection, installation dimensions, ranges of adjustment						
Nominal diameter	DN	10				15		
Connection DIN EN ISO 228	G	1/4" (8)	3/8" (10)	1/2" (15)	3/4" (20)	3/8" (10)	1/2" (15)	3/4" (20)
	G1'	1/2" (15)	1/2" (15)	1/2" (15)	1/2" (15)	1/2" (15)	1/2" (15)	1/2" (15)
		3/4" (20)	3/4" (20)	3/4" (20)	3/4" (20)	3/4" (20)	3/4" (20)	3/4" (20)
		1" (25)	1" (25)	1" (25)	1" (25)	1" (25)	1" (25)	
Installation dimensions in mm	H	133	133	133	133	134	134	134
	H1'	ca. 28	ca. 28	ca. 28	ca. 28	ca. 30	ca. 30	ca. 30
	h	12	12	15	16	12	15	16
	SW	27	27	27	27	30	30	30
	do	6	6	6	6	9	9	9
Weight	kg	0,74	0,74	0,74	0,74	0,86	0,87	0,92
Range of adjustment	bar	50-630	50-630	50-630	50-630	50-250	50-250	50-250

¹only for the version with positionable angled body and according to choice of outlet connection size

■ MAIN DIMENSIONS, INSTALLATION DIMENSIONS

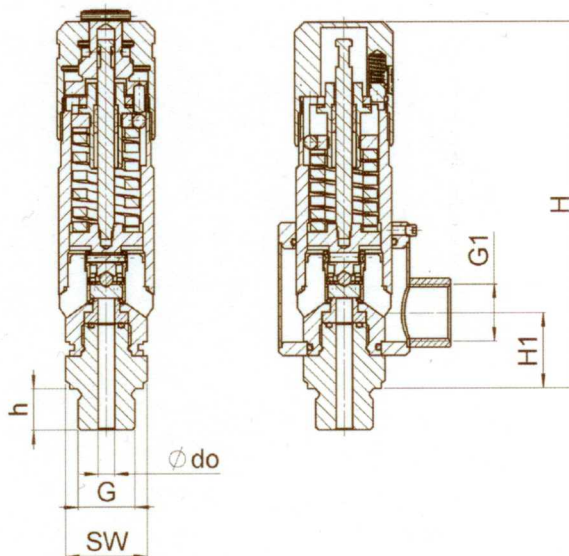

■ INDIVIDUAL SELECTION / VALVE CONFIGURATION

Series	Valve version	Medium	Lifting device	Nominal diameter DN	Connection type		Connection size		Seal	Options	Set pressure	Quantity
					Inlet	Outlet	Inlet	Outlet				
	s	G	K	10	m	-	8	-	MD / PAI		70,0	5
	t	G	O	15	m	f	15	20	MD / PAI		300	2
		G			m				MD / PAI			
		G			m				MD / PAI			

■ CAPACITY TABLE

Series : Blowing-off rates at 10% above set pressure			
Nominal diameter DN	10	15	
Set pressure bar			
Air	50	787	1867
	60	941	2233
Nm ³ /h	70	1095	2600
	80	1250	2967
	90	1404	3333
	100	1559	3700
	110	1713	4067
	120	1868	4433
	130	2022	4800
	140	2177	5167
	150	2331	5533
	160	2486	5900
	170	2640	6266
	180	2795	6633
	190	2949	7000
	200	3104	7366
	210	3258	7733
	220	3413	8100
	230	3567	8466
	240	3722	8833
	250	3876	9200
	260	4031	
	270	4185	
	280	4340	
	290	4494	
	300	4649	
	310	4803	
	320	4958	
	330	5112	
	340	5267	
	350	5421	
	360	5576	
	370	5730	
	380	5885	
	390	6039	
	400	6194	
	410	6348	
	420	6503	
	430	6657	
	440	6812	
	450	6966	
	460	7121	
	470	7275	
	480	7430	
	490	7584	
	500	7739	
	510	7893	
	520	8048	
	530	8202	
	540	8357	
	550	8511	
	560	8666	
	570	8820	
	580	8975	
	590	9129	
	600	9284	
	610	9438	
	620	9593	
	630	9747	